



Cineplex Media 2016 Canadian Optimist Championship
August 18-24, Ashbridge's Bay Yacht Club, Toronto
Organizing authority is Ashbridge's Bay Yacht Club
with the endorsement of the Canadian Optimist Dinghy Association

Sailing Instructions – Team Racing With Ammendment 1

[DP] Denotes an instruction or rule for which a penalty is at the discretion of the jury.

[NP] Denotes that a breach of this rule will not be grounds for a protest by a boat, changing rule 60.1(a).

1 RULES

1.1 The regatta will be governed by the rules as defined in The Racing Rules of Sailing (RRS), as amended and prescribed by Sail Canada (http://www.sailing.ca/files/SC_Prescrip_Arbit_2013_16.pdf), and by the 2016 Optimist Class Rules (http://www.optiworld.org/uploaded_files/Document_2304_20160103144814_en.pdf.)

1.2 Appendix D will apply including D.2.2 (single flag procedure).

1.2.1 D1.1(d) is deleted.

1.2.2 The first sentence of D3.1(d)(3) is deleted and replaced by: "when the boat has broken rule 1 or 2, rule 14 when she has caused damage or injury, or a rule when not racing, either the boat's score may be increased, or half or more race wins may be deducted from her team, or no penalty may be imposed."

1.2.3 When a boat starts and finishes, and breaks rule 28.1 by failing to sail the course described in the sailing instructions, 6 points shall be added to her score without a hearing. This changes rule A5.

1.3 Rule 26, Starting Sequence is modified to shorten the sequence: see instruction 11.4.

1.4 [DP] Personal Flotation

1.4.1 The first sentence of rule 40 is deleted and replaced by: 'Each competitor shall wear a personal flotation device (PFD) according to class rule 4.2 (a), properly secured at all times while on the water except when temporarily adding or removing clothing.'

1.4.2 The preamble of rules Part 4 is changed to:
Part 4 rules apply only to boats racing. However, rules **40 and 55** apply at all times when boats are on the water.

2 NOTICES TO COMPETITORS

- 2.1 Notices to Competitors will be posted on the official notice board(s) located in the main regatta tent at ABYC. As a courtesy only, an attempt will be made to also post notices on the event website: <http://www.2016opticanadians.com>.

3 CHANGES TO SAILING INSTRUCTIONS

- 3.1 Any change to the schedule of races will be posted by 1800 on the day before it will take effect. Any other change to the sailing instructions will be posted before 0900 on the day it will take effect.
- 3.2 Sailing instructions may be changed orally by the Race Committee and/or the Umpires before the warning signal, when flag L is displayed. It is the responsibility of each team to obtain any oral instructions given. Such changes will also be communicated to the coaches on VHF channel 71.
- 3.3 Changes to the format of racing and the publication of the schedule of subsequent races made on the water will be announced as described in 3.2.

4 SIGNALS MADE ASHORE

- 4.1 Signals made ashore will be displayed on the Main Flag Pole, just SW of the main clubhouse.
- 4.2 When flag AP is displayed ashore and lowered, the next signal (flag 'D', flag 'N' or a modification to flag 'AP') will be made 1 minute later. This changes Race Signal 'AP'.
- 4.3 [NP][DP] When flag 'D' is displayed ashore with one sound signal, boats may commence launching, and a warning signal will be made not less than 45 minutes later for the fleet(s)/division(s) launching.
- 4.4 [NP][DP] If flag 'D' is lowered with two sound signals, launching shall cease until further signals are made.

5 RACING FORMAT & NUMBER OF RACES

- 5.1 The event will be a four-boat against four-boat team race. A team may have five members, with any four competing in a race, provided that the fifth competitor remains in the area designed for coaches, or ashore, from the warning signal of that race until that race has been completed.
- 5.2 A maximum of 16 teams will be accepted.
- 5.3 Appendix 'A' shows the intended racing format. The format may be modified during the event in a fair and practical way as solely determined by the Race Officer, taking into account the entries, weather considerations, time constraints, and any other relevant factors.
- 5.4 The race committee may decide not to run a re-sail if the result of that race is not relevant to the progress of any team to the next round.

6 SCHEDULE

- 6.1 No warning signal will be made after 1600.

Day	Time	Event
Sunday August 21	1800	Deadline for registration for team racing
Monday August 22	0830	Lunches Available (upstairs in clubhouse) Coaches Meeting (in Tent)
	0855 EARLY!	Launch Commences
	0955 EARLY!	First Warning Signal: Team Racing

7 FLEET/DIVISION FLAGS & START SEQUENCE

7.1 The Class flag will be an Optimist logo on a yellow background.

7.2 Teams will be assigned to the first flight of the event randomly, which will determine the race number of their first competition. This will be published not later than 0830 the day of the event. Subsequent starts will be determined by the results of the first and subsequent flights.

7.3 Teams will be assigned a phonetic letter (Alpha, Bravo, etc.) which will be used to identify which teams are competing.

8 RACING AREA

The Team Racing course is immediately South East of the ABYC headland. See Appendix 'B'.

9 THE COURSE

9.1 Appendix 'C' shows the course, and describes the order in which marks are to be rounded, the side on which each mark is to be left, and the descriptions of the marks.

9.2 The Race Committee may move marks of the course. Rule 33 will not apply. The moving of a mark by the Race Committee will not be grounds for a boat to request redress. This changes rule 60.1(b).

9.3 Courses will not be shortened. This changes rule 32.

10 MARKS

10.1 Marks 1, 2, 3, and 4 will be orange tetrahedrons.

10.2 Start and finish pins will be yellow cylinders.

11 THE START

11.1 The starting line will be between the staff or halyard displaying an orange flag on the signal boat and the starting mark.

11.2 Boats whose warning signal has not been made shall avoid the starting area during the starting sequence for other races.

11.3 The race number and competing team identification letters will be posted on the signal boat before the warning signal. When the race number is displayed in this way, it overrides all prior communications, schedules, or instructions. The Race Committee may at any time remove a particular race from the published sequence and run it at a later time.

11.4 Rule 26 is modified to change the starting sequence as follows:

Signal	Minutes before Start	Sound Signal	Visual Signal
Warning	3	One	Class flag displayed
Preparatory	2	One	"P" flag displayed
One-minute	1	One	"P" flag removed
Starting	0	One	Class flag removed

11.5 When an individual recall is made, flag X will be displayed for up to 1 minute. This changes rule 29.1

11.6 The race committee will attempt to call the sail numbers of OCS boats with a loud hailer. The following will not be cause for redress: failure to hail a boat; the order of sail numbers called; failure to hear a hail. This changes rule 60.1(b).

11.7 A boat starting later than 2 minutes after her starting signal will be scored Did Not Start (DNS) without a hearing. This changes rules A4 and A5.

12 THE FINISH

The finishing line will be between the finish mark and the staff or halyard displaying an orange flag on the race committee boat.

13 TIME LIMITS AND ABANDONMENT

13.1 If no boat has reached the first mark in 10 minutes the race will be abandoned.

13.2 If no boat has finished within 20 minutes the race will be abandoned.

13.3 Boats failing to finish within 3 minutes after the first boat sails the course and finishes will be scored Did Not Finish (DNF) without a hearing. This changes RRS 35, A4 and A5.

13.4 The target time is 6 minutes. Failure to meet the target time will not be grounds for redress under RRS 62.1(a).

13.5 The Race Committee may abandon a race for any reason. This changes rule 32.

13.6 Abandonment may be signalled orally by the Race Committee and/or the umpires. Abandoned races may be re-sailed, and if so, a new warning signal will be made as soon as practical. This changes rule 32 and Race Signals.

14 UMPIRING AND FLAGS

14.1 The event will be umpired in accordance with Appendix D as modified by these sailing instructions.

14.2 The required red protest flag shall be attached to the competitor, clothing or PFD, and be capable of being displayed at arm's length. To signal a protest, the flag shall be displayed from a concealed position to a position where it is easily visible to the protested boat and Umpires.

15 PROTESTS AND REQUESTS FOR REDRESS.

15.1 For protests and requests for redress other than protests under a rule listed in rule D2.2, competitors shall inform an umpire or the Race Committee at the first reasonable opportunity upon finishing. The umpires will, when appropriate, hear protests and requests for redress while afloat.

15.2 The protest time limit for competitors is two minutes after finishing and for the Race Committee or Jury it is 60 minutes after the last boat finishes the last race of the day.

15.3 A hearing may be declined if it is not relevant to progress to the next round. This changes rule 63.1

15.4 When a hearing ashore is necessary, the schedule will be published no later than 30 minutes after the end of the protest time limit.

15.5 In addition to instructions marked [NP], breaches of class rules will not be grounds for a protest by a boat. This changes rule 60.1(a). Penalties for these breaches will be at the discretion of the jury.

16 SCORING

16.1 Rule D4 is deleted and replaced by:

Each team will race at least two times. Teams having lost two times are eliminated from the competition and may return ashore. The two remaining teams will race the SAIL OFF. This is a set of three races after which the two of them becomes the winner of the team racing event.

- 16.1.1** If only one race of the SAIL OFF is completed, the winner of that race will be the winner of the team racing event. If only two races are completed in the SAIL OFF, and the races are not won by the same team, the winner of race 23 will be the winner of the team racing event.
- 16.1.2** If flight VI (semi final) is not completed, the winner of race 23 will be the winner of the team racing event, and the winners of races 27 and 28 will be ranked using, in order:
- (a) the number of races won when the two teams met
 - (b) the total points scored in all races against common opponents
 - (c) the order in which they registered for the team racing event

17 SAFETY REGULATIONS

- 17.1** [NP] [DP] Boats shall not leave the harbour until Flag 'D' is raised.
- 17.2** [NP] [DP] All Competitors shall sail past the stern of the signal boat on starboard tack prior to the first race of the day to check in with the race committee, or upon returning to the race area if they have left it for any reason.
- 17.3** [NP] [DP] A boat that retires from a race or leaves the racing area shall notify a race committee, safety, or jury boat as soon as possible.
- 17.4** [NP][DP] All competitors will sign out and pick up a wrist band when they pick up their lunches. All competitors must sign back in and return their wrist bands at the main tent within 60 minutes of the last boat finishing for the day,. Failure to do so may result in a 25% scoring penalty on the final race of the previous day (Canadian Optimist Championship Qualifying Series), without a hearing; this changes rule A.5.

18 REPLACEMENT EQUIPMENT

[NP] [DP] Substitution of damaged or lost equipment will not be allowed unless approved by the race committee. If the damage occurs less than 2 hours before the first scheduled start on a racing day, or before the start of the last race of the day, provisional verbal permission shall be requested from the race committee, and if granted, the written permission of the race committee shall be requested before the end of the protest time limit at the end of the day in which the substitution takes place; re-measurement may be required. Equipment Substitution Forms will be available at the protest desk.

19 EQUIPMENT AND MEASUREMENT

- 19.1** A boat or equipment may be inspected at any time for compliance with the class rules and sailing instructions. On the water, a boat may be instructed by the race committee to proceed immediately to a designated area for inspection.
- 19.2** [DP] A boat shall register only one sail number and shall have that number on the sail.
- 19.3** [NP][DP] Determination of the legibility of sail numbers will be at the discretion of the Chief Measurer.

20 ADVERTISING

[DP] [NP] Boats may be required to display advertising supplied by the organizing authority.

21 OFFICIAL BOATS

Official boats will be marked as follows:
Jury will fly a white flag with the letter "J" on it
Safety Boats will fly a yellow flag with a red vertical stripe.

22 [DP] SUPPORT BOATS

- 22.1** Support boats shall register with the organizing authority prior to the first scheduled race.
- 22.2** Each support boat will be provided with a numbered flag, and it shall show this flag when on the course.

22.3 Each race course has an exclusion zone, described and illustrated shown on the course diagrams.

22.4 [DP] Exclusion Zone: Team leaders, coaches, spectators and other support personnel shall stay outside of the exclusion zone from the time of the preparatory signal for the first start until all boats have finished or retired or the race is postponed, recalled, or abandoned.

22.5 At the request of the race committee, coach boats may enter the exclusion zone to offer or provide outside assistance to a boat.

22.6 [DP] In an emergency situation, a coach may, on their judgement, enter the exclusion zone to aid a boat for which it is responsible. Such action may be deemed to be in violation of Rule 41 for the boat so aided, which may be scored Did Not Finish without a hearing. This changes rule A5.

22.7 [DP][NP] Support boats are required to have a working VHF radio. The channel used by the race committee will be 71.

23 DISCLAIMER OF LIABILITY

Competitors participate in the regatta entirely at their own risk. See RRS 4, Decision to Race. The organizing authority will not accept any liability for material damage or personal injury or death sustained in conjunction with or prior to, during, or after the regatta.

24 INSURANCE

[NP] [DP] Each participating boat shall be insured with valid third-party liability insurance with a minimum coverage of \$1 million per incident

25 HARBOUR AND SITE

25.1 [DP] [NP] Competitor boats shall be kept in their assigned places in the boat park.

25.2 [DP] [NP] Support boats shall be kept in their assigned places in the harbour.

25.3 [DP] [NP] Automobiles and trailers must be parked in accordance with the directions of the Organizing Authority.

26 RADIO COMMUNICATION

[DP] A boat shall neither make radio transmissions while racing nor receive radio communications not available to all boats. This restriction also applies to mobile telephones.

27 TRASH DISPOSAL

[NP] [DP] Trash and recyclables may be placed aboard race committee and other official boats.

28 RIGHTS TO USE NAME AND LIKENESS

By participating in this event, competitors automatically grant to the organizing authority and the event sponsors the right, in perpetuity, to make, use, and show, at their discretion, any photography, audio and video recordings, and other reproductions of them made at the venue or on the water from the time of their arrival at the venue, until their final departure, without compensation.

APPENDIX 'A' – Team Racing Event Format

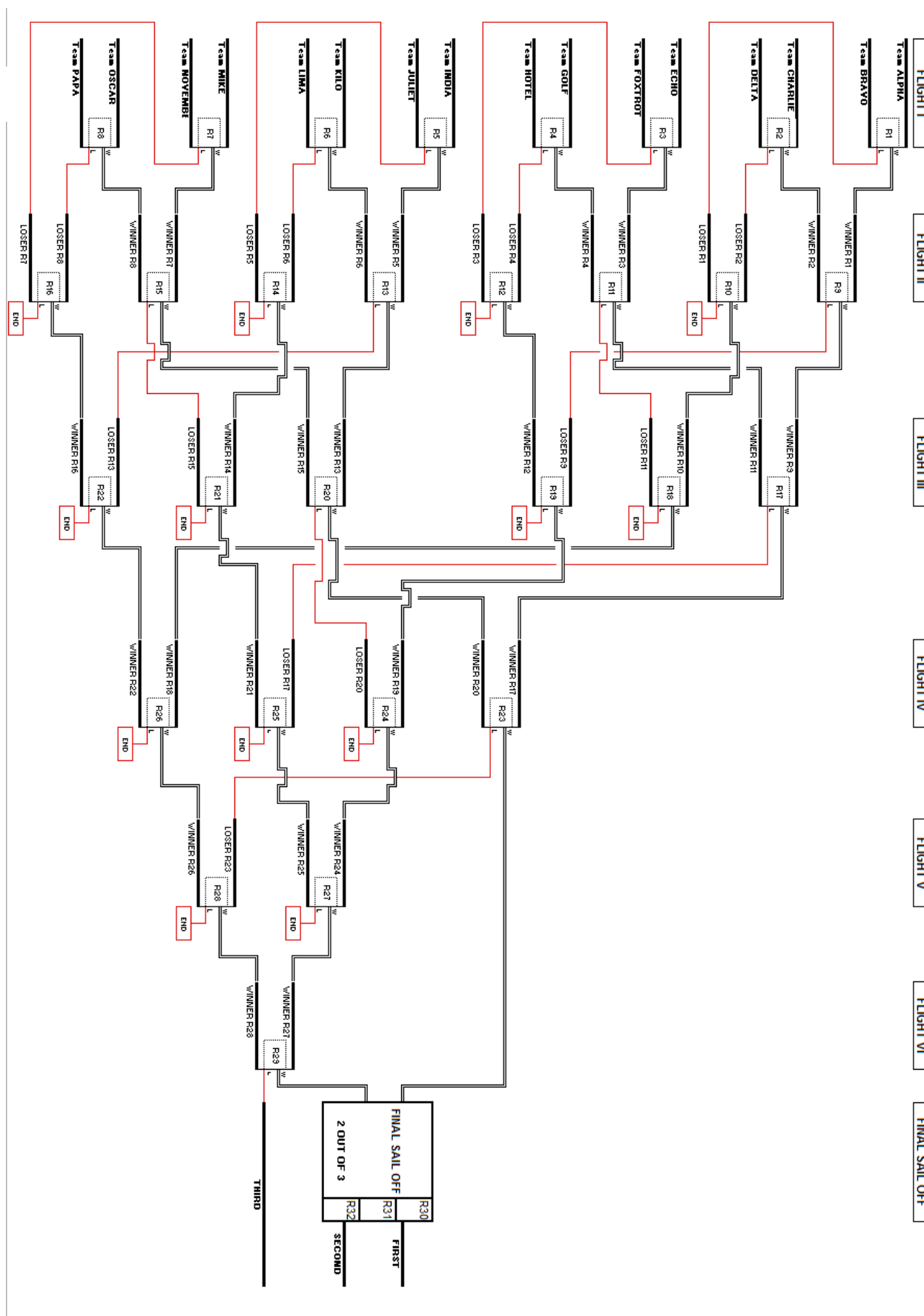

APPENDIX 'B' – Race Area



APPENDIX 'C' – Team Racing Course

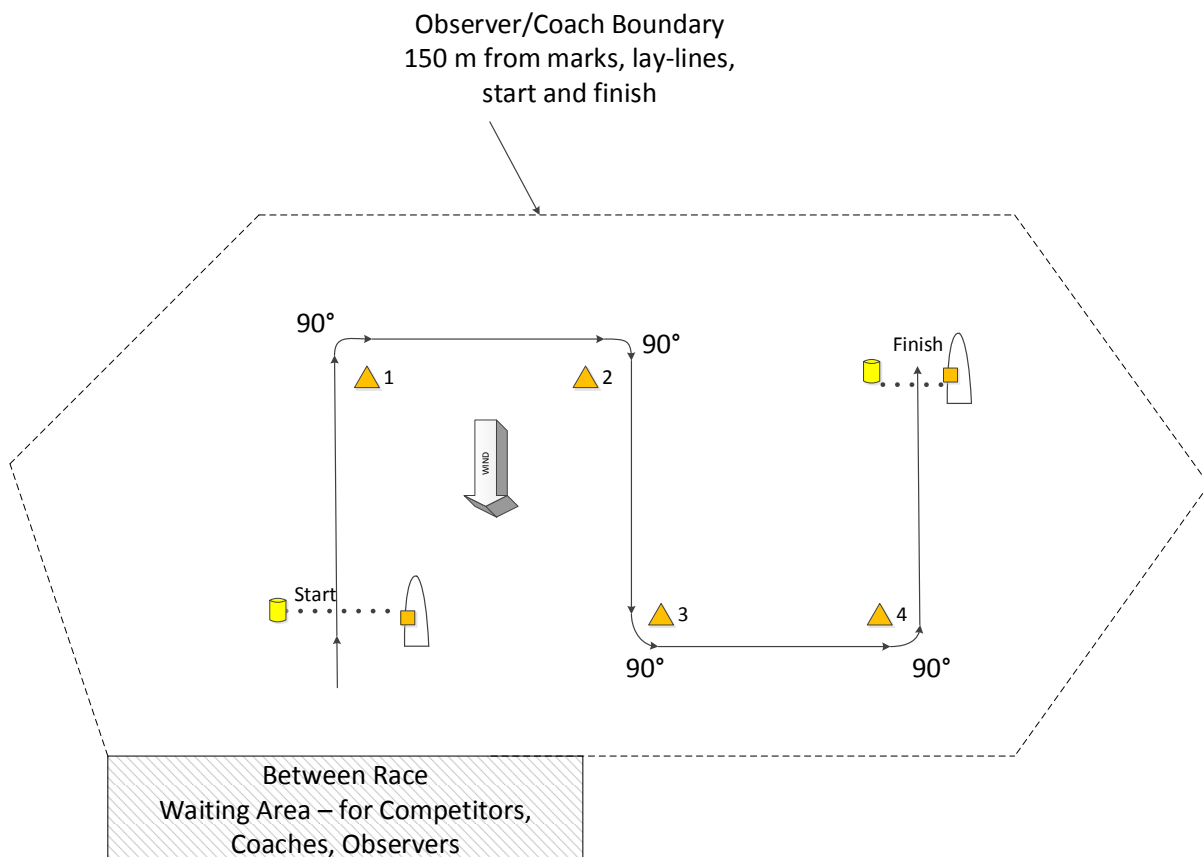

Sequence:

Start – 1 (to starboard) – 2 (to starboard) – 3 (to port) – 4 (to port) – Finish

Marks 1, 2, 3, 4 are ORANGE tetrahedrons. The start and finish pins are YELLOW cylinders.